

**OVEN INDUSTRIES, INC.**



**OPERATING MANUAL**  
**Model 5C7-550 (A)**



**THERMOELECTRIC MODULE**  
**TEMPERATURE CONTROLLER**

**CAUTION**: Always be careful around heaters and TE modules, their related heat sinks, or other parts of the thermal system. Do not come into contact with a hot or very cold surface. Use a thermal fuse for additional protection. Do not leave an active thermal system unattended without taking all necessary safety precautions. Follow all safety requirements at your location and for your thermal system.

## TABLE OF CONTENTS

	Page
Features .....	1
Description .....	2
Block Diagram .....	3
Connections and Adjustments.....	4
Mounting Connection .....	5
Functional Diagram .....	6
Set-up Instructions .....	7
Application Note .....	9

In no event shall Oven Industries, Inc. be liable for any damages whatsoever (including without limitation, damage for loss of business profits, business interruption, loss of business information, or any other pecuniary loss) arising out of the use or inability to use this Oven Industries, Inc. product, even if Oven Industries, Inc. has been advised of the possibility of such damages.

## Features

- Designed for controlling **THERMOELECTRIC** MODULES
- Solid State “H” Bridge operation
- BI-Directional Control (Seamless Transition)
  - **Green** LED Heating mode
  - **Blue** LED Cooling mode
- Input voltage: 3 to 28vdc: TE module Voltage.  
6 to 28vdc: Control circuit
- Self contained  $\pm 0.1$  amp to  $\pm 12.5$  amps load current. @ + 25°C ambient
- Controls up to 350 watts output power, Heating and Cooling.
- Control Temperature Range:
  - -20°C to +100°C via TS67 sensor
  - 0°C to +150°C via TS104 sensor
- Select sensor via PCB dip switch
- Proportional (P) & Integral (I) control algorithm
- Temperature resolution 0.1°C (nominal )
- Adjustable Bandwidth: 1.0°C to 16°C
- Adjustable Integral Rate: 0 to 2.55 repeats per minute
- Pulse width modulated output with base frequency of 1.0kHz
- Temperature Control stability:  $\leq$  to  $\pm 0.1^\circ\text{C}$
- Hookup via pluggable barrier strip
- Power Resolution (Load Circuit) 0.4%

## General Description:

Oven Industries Model 5C7-550 series is an economical, open board temperature controller especially designed to operate thermoelectric (Peltier effect) modules. This controller will provide temperature control of thermoelectric modules up to 350 watts (28vdc X 12.5 amps = 350 watts).

The controller contains a solid state "H" bridge. This provides BI-directional (heating and cooling) control for one or more independent TE modules, or in conjunction with auxiliary or supplemental resistive heaters for both cooling and heating applications. The control of the "H" bridge is designed to provide a seamless transition between heating and cooling. (no dead spot in the control function during transition between heating and cooling) The controller utilizes Pulse Width Modulation (PWM) to control the power level in the thermoelectric module. The base frequency is 1.0kHz. The output power resolution is one of  $\pm 250$  steps in the load circuit control. This provides 0.4% power resolution in both the heat and cool mode.

The controller provides an indication of the heat or cool operation mode. A Green LED is used to indicate a heating mode. A Blue LED is used to indicate a cooling mode.

Both the Green and Blue LED being on indicate an open sensor. The controller load circuit is off for an open sensor.

This controller was designed with a proportional / integral control algorithm to provide the most precise control at the most economical cost. The proportional bandwidth is adjustable from 1.0°C to 16°C and the integral rate is adjustable from 0 to 2.55 repeats per minute. These adjustments permit optimizing individual thermal systems. In a well

designed thermal system end point control can be  $\pm 0.1^\circ\text{C}$ .

Model 5C7-550 will accept a TS67 sensor (-20°C to +100°C) or will accept a TS104 sensor (0°C to +150°C). The sensor selection is made via a PCB mounted dip switch. Model 5C7-550A has a remote set temperature adjust option. This model includes remote potentiometer and temperature scale. Also, available digital temperature display Model 5C7-551.

The controller is capable of providing up to 12.5 amps of current for modules rated 3 through 28 volts dc with an ambient temperature of 0°C to +50°C. (refer to mounting instructions)

The controller will operate with a single power supply over the range of 6vdc to 28vdc. If the TE modules require lower voltages, then two supplies are required. One supply for the load 3vdc to 28vdc and one for the control circuit 6vdc to 28vdc (the control circuit will draw less than 100ma). The load circuit power supply may not be a higher voltage than the logic power supply. Fuse F1 will fail if the power supplies are not correctly selected.

The controller electronics have a set point stability of  $< \pm 0.1^\circ\text{C}$  after one hour of stabilization @ 25°C ambient.

The controller has a temperature resolution of 0.1°C.\* This will provide an end point control of up to  $\pm 0.1^\circ\text{C}$ . To achieve this control requires that the thermal system be well designed, the control sensor be correctly located, and the system be optimally tuned. When selecting the temperature sensor location, we suggest that the sensor be located thermally close to the working side of the TE module. Minimum delay in the temperature sensor seeing the temperature change in the TE Module temperature is preferred.

# Block Diagram

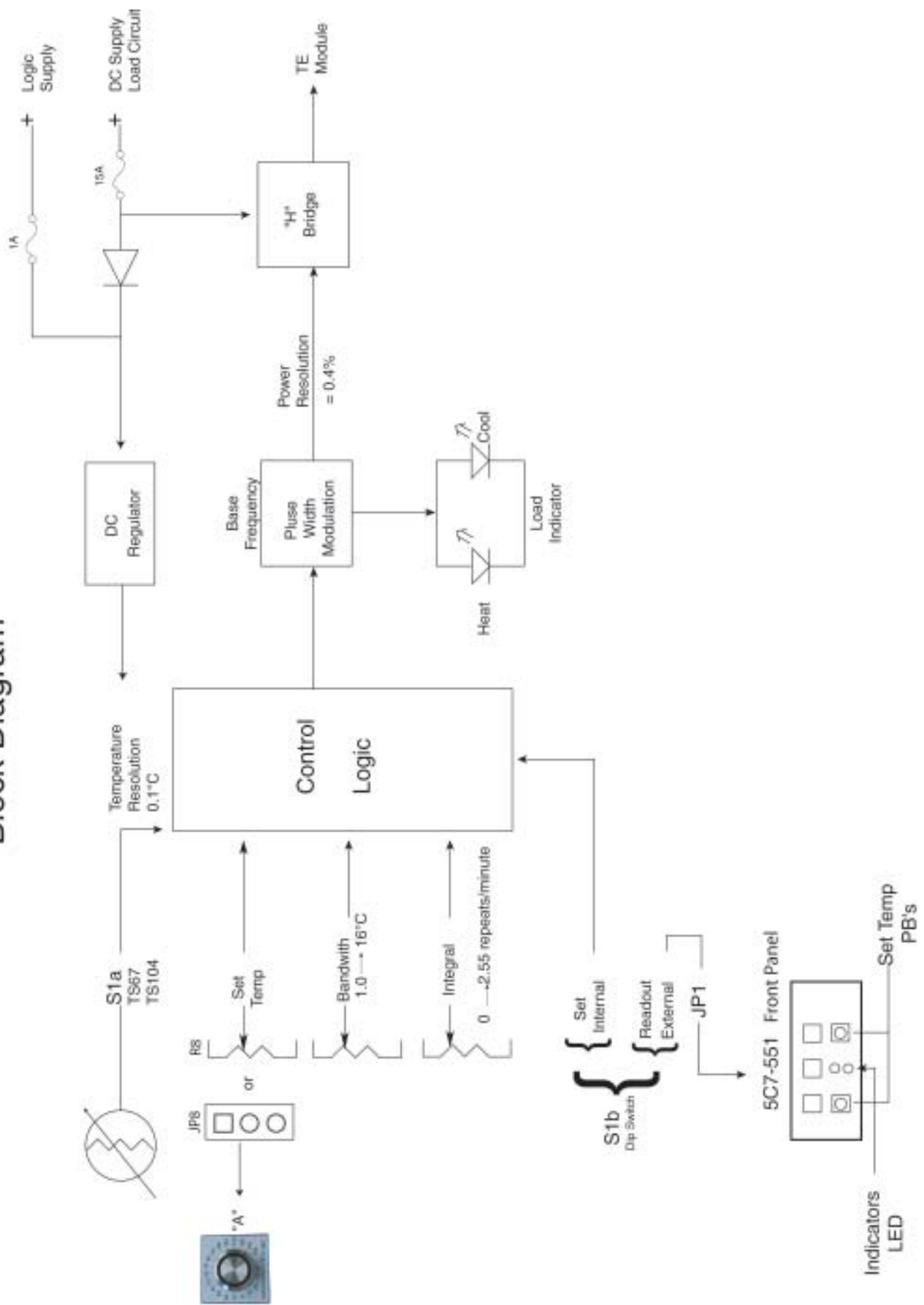

# Connections and Adjustments

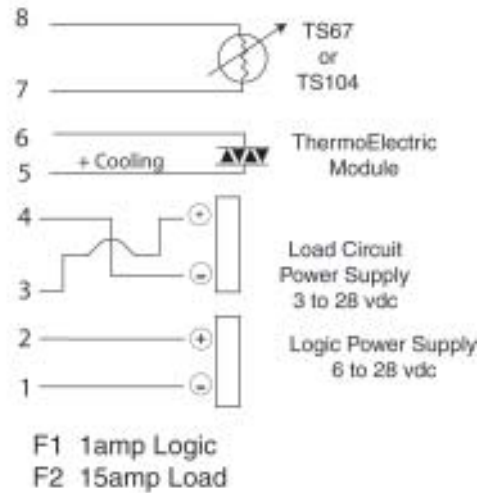
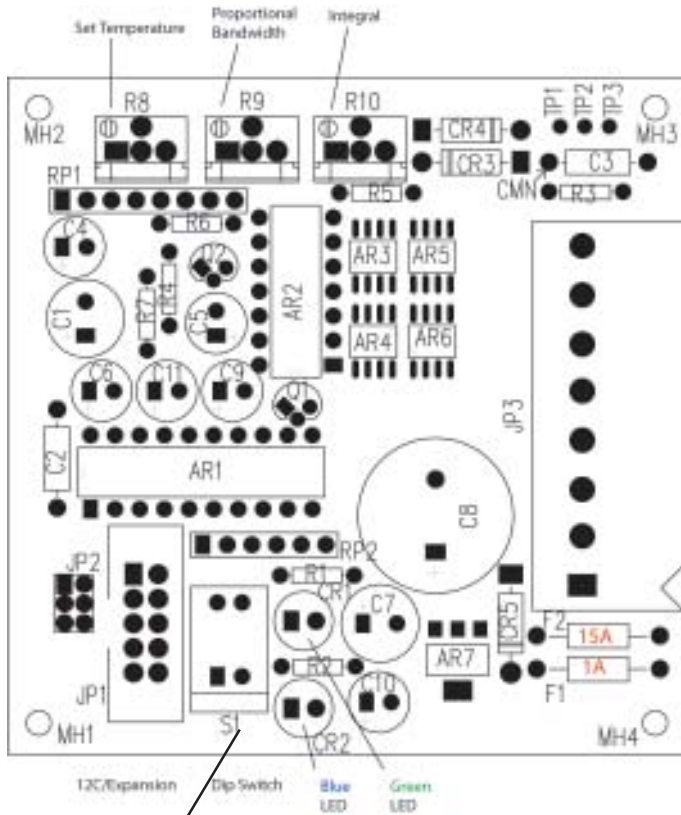

- S1
- |   |   |   |
|---|---|---|
| a | b |   |
| ■ | ■ | Sensor TS67<br>Standard Controller              |
| ■ | ■ | Sensor TS104<br>Standard Controller             |
| ■ | ■ | Sensor TS67<br>Remote Display I <sup>2</sup> C  |
| ■ | ■ | Sensor TS104<br>Remote Display I <sup>2</sup> C |

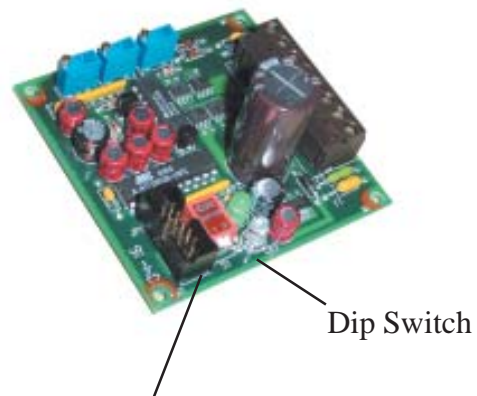

Expansion Port for Temperature Display:  
Uses I<sup>2</sup>C Communication

## 5C7-551 Cable Connection

Connect cable key into proper slot on connector. If cable is not properly inserted display will not work properly.

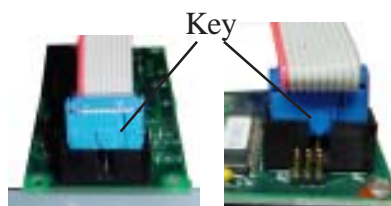

## Model 5C7-550 Series Controller

### MOUNTING

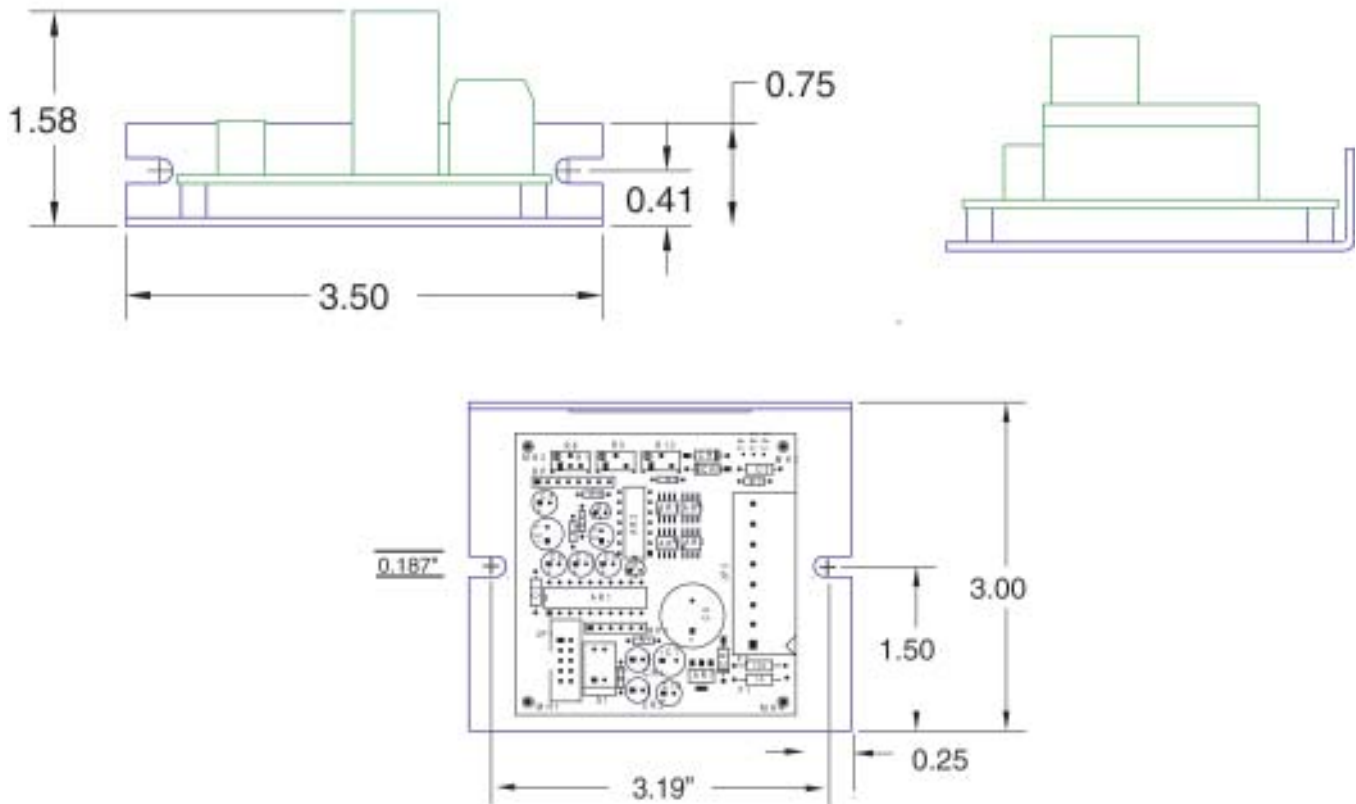

The controller should be mounted in a well-ventilated location. Any air movement over the controller will improve the thermal environment of the controller.

Model 5C7-550 uses surface mount elements for the electronic “H” bridge. These components have low on resistance of 0.0048 ohms. However it is necessary to consider the ambient temperature when deciding the permissible load current.

The controller will provide full load capability of 12.5 amps, @ 25°C ambient temperature. This current must be reduced to 10.0 amps @ 50°C ambient. Both ratings are for a 100 % duty cycle. When the controller is in the proportional bandwidth the “H” bridge power dissipation will be reduced in proportion to the load circuit duty cycle.

The controllers’ load current is reduced to  $(10.0/12.5 = 80\%)$  @ 50°C ambient. This is also equivalent to an 80% duty cycle of 12.5 amp load @ 50°C ambient.

## 5C7-550 Functional Diagram

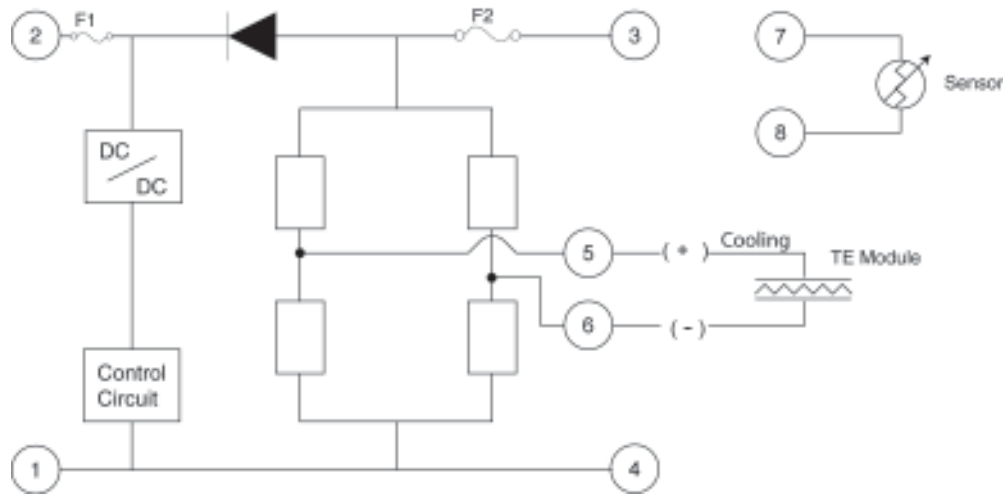

The controller load circuit power supply is 3vdc minimum and 28vdc maximum: JP3 3 (+) JP3 4 (-). This supply will provide the load current and should be selected for the TE Modules used. If this supply is less than 6vdc a second power supply of 6vdc minimum will be required for the logic power supply, JP3 2(+), JP3 1(-).

**CAUTION:** The load circuit power supply may not be a higher voltage than the logic power supply. Fuse F1 will fail if the power supplies are not correctly selected.

The controllers' temperature range and temperature sensor is selected by a dip-switch S 1.

TS67 series: -20°C to 100°C

TS104 series: 0°C to 150°C

If the control sensor is open or shorted both LED's, (CR1: CR2) will be on.

## Model 5C7-550 Set Up Instructions

Connect the appropriate DC power supply to the controller.

For single power supply operation (6vdc to 28vdc) connect to JP3 pin 3 (+) and pin 4 (-). When it is required to operate a TE Module under 6vdc (3vdc to 6vdc) the control logic requires a minimum of 6vdc connected to JP3 pin 2 (+) and pin 1 (-). The lower power supply for the TE Module connects to JP3 pin 3 (+) and pin 4(-).

Connect the TE Module to JP3 pin 5 (+ cooling) and JP3 pin 6 (-). Maximum current is 12.5amps (see temperature-derating chart).

Select the temperature sensor series: TS67 (-20°C to +100°C) S1a up: TS 104 series (0°C to 150°C) S1a down.

Connect the selected temperature sensor to JP3 pin 7 & 8.

Position S1b up for ‘No remote readout’ down for “remote temperature readout”

If “A” version of the controller has been purchased, install the remote connector into R8 connector.

Proportional Bandwidth is the temperature band in which 0% to 100 % power will be applied to the load, 100% cool ≤ output ≤100% heat, 0% no heat or cool. The bandwidth adjustment provides bandwidths of 1.0°C to 16°C. Clockwise rotation increases the bandwidth setting. Proportional control eliminates the temperature cycling inherent in deadband control. Proportional control reduces the percentage of power applied to the load, as the temperature reaches the temperature set point. The “H” Bridge provides for a seamless transition from heating to cooling. The 0 % power is defined as no heat or cool. As the control temperature varies above or below set point the controller will apply either heating or cooling power.

Integral gain shifts the proportional bandwidth with respect to the set point to compensate for droop. This value is expressed in repeats per minute and acceptable values that may be selected are 0 to 10 repeats per minute. Integral gain is increased by clockwise adjustment.

The control potentiometers, set temperature, proportional bandwidth, and integral gain are 25 turns from 0 to maximum setting. The potentiometers provide a voltage to the control circuit of 0 to 5vdc. This voltage is a linear scale of the adjust range of the function.

- R8 Set Temperature (clockwise to increase) the temperature adjustment is scaled for -20°C to 150°C or 0 to 5.0 volts. Test point TP3 is the voltage for set temperature.
- R9 Controller Bandwidth (clockwise to increase) scaled 0 to 5vdc = 1.0°C to 16°C. Test point TP2 is the voltage for bandwidth.
- R10 Integral Gain (clockwise to increase) scaled 0 to 5vdc for 0 to 2.55 repeats per minute: Test Point TP1 is the voltage for integral gain.

The test points are measured with regards to the negative side of the power supply. JP3 pin 1 & 4

Separately monitor the control temperature. (Option 5C7-551 Digital Display)

Apply power to the system, and note which of the LED’s are on. Green heating, Blue cooling. Adjust the set temperature to the desire value.

## Tuning the system

Adjust the integral gain to 0 CCW. Adjust the bandwidth to 0 CCW. The system temperature should be cyclic. Adjust the bandwidth CW, counting the number of turns until a small-sustained temperature cycle is observed. Note the time of this temperature cycle. This time is the natural period of the system. Turn the bandwidth control CW the same number of turns as noted thus doubling the bandwidth. Adjust the integral gain to the reciprocal of the natural period. Each turn of the integral potentiometer is 0.10 repeats per minute. Monitor integral setting at TP1.

The controllers' bandwidth may be measured with a voltmeter at TP2. The bandwidth setting is distributed over the heat and cool function. A bandwidth of 10 degrees provides 5 degrees heating and 5 degrees cooling.

The integral function monitors the difference between the set temperature and the actual temperature. The integral function will slowly change the output power until the difference between the set temperature and the actual temperature is 0. This integration takes place over fixed intervals. The intervals are expressed in repeats per minute. (RPM) The integral function should not take place so rapidly that the system starts to oscillate.

Nominal settings for a small rather fast responding TE system would be: Bandwidth 10 degrees. TP2 = 3.0 volts. Integral: 0.5 RPM. TP1 = 0.98 volts

The above values are ballpark values and should be trimmed for optimal system performance. These values should be recorded for use in other similar systems.

The sensor placement is part of the overall thermal system. Many times the sensor placement can be change to improve the system performance. The sensor placement needs to be selected to represent the desired temperature while still maintaining a close thermal tie to the source of the heating and cooling.

In a properly adjusted system it is reasonable to see endpoint control of temperature that is about twice the temperature resolution of the controller. Model 5C7-550 has a set temperature resolution of 0.1°C.

**Model 5C7-551 remote readout:** **CAUTION:** When changing from °C to °F you must reset the set temp.

To use the remote readout, connect the cable from the readout (model 5C7-551) to the connector JP1 on Model 5C7-550. The readout will indicate the actual temperature of the control sensor. Apply power to the system and note the temperature on the three-digit readout. The readout displays the temperature of the control sensor. If this sensor is open the display will indicate -21°C. If the sensor is shorted the display will indicate 160°C. **The readout will display the actual temperature for either on board or remote set "A" suffix set temperature selections.**

If the readout is also to be used for selecting the set temperature, switch S1b is positioned to the down position. Note this switch must be positioned before power is applied for the controller to "read" the switch position. To display the set temperature, depress the up or down push button and note the set temperature. The set temperature can be adjusted by holding the up or down pushbutton and observing the set temperature change. Continue to hold the push button until the desired set temperature is observed. Release the push button and the controller will move the control point to the new set temperature.

The readout may be set to indicate in °C or °F. An LED on the front panel indicates this selection. To change this selection: Depress both the up and down button and then apply power to the controller. The display will indicate -S-. The up button will toggle °C and °F. The LED will indicate which is selected. To store this selection depress the down button. The display will return to normal operation, and the selected mode, °C or °F, will be indicated. You must confirm set temperature in new selected mode.

## Application Note

### Cold Plate or Solid-State Chamber Cooler

There are numerous applications where the need for heating and cooling are required. Small environmental chambers can be constructed by using a **ThermoElectric** air-to-air heat exchanger. An insulated chamber can be made by using an insulated cooler. Many sizes are available from your local Big Box store. The air-to-air refrigeration is mounted through the wall of the cooler. A power supply and model 5C7-550 controller completes the system.

Select the air-to-air system with a fan on both the sink and working side. The temperature sensor can then be mounted in the air stream inside the cooler near the working surface of the air-to-air exchanger. The “A” version controller will provide a remote set temperature or remote display option can provide digital display and digital set of temperature.

The controller can provide 12.5amps of load current. Numerous air-to-air exchangers are available. Select a 24-volt system and one sized for the volume of cooler selected.

